

## PERFORMANCE DATA SHEET NEMA PREMIUM NR CAN NEMA 12 - 12

Catalogue #: MPP-88

HP	kW	Voltage	S.F. @ 60Hz	EFF.	P.F.	Frame	Design	L.R. Amps
150	111,90	575	1,15	95,8%	0,82	447T	B	868

60 Hz								
FLA							Code	F.L. RPM
208	230	416	460	480	575	600		
/	/	/	/	/	143,2	/	G	1188

50 Hz							
FLA			S.F. @ 50Hz	Efficiency	Power Factor	Code	F.L. RPM
190	380	415					
/	/	/	/	/	/	/	/

Wgt. Lbs	PH	Duty	Insul. Class	Amb.	Elevation	Temp. Rise° C
1800	3	Cont.	F	40°C	1000M (3300 Ft)	< 80

% Efficiency		% Power Factor		Torque		Winding Resist. Ω	Safe Cold Start (Secs)
Full Load:	95,8%	Full Load:	0,82	Full Load Ft/Lbs	663,1		
3/4 Load:	95,1%	3/4 Load:	0,79	Locked Rotor %	140		
1/2 Load:	94,5%	1/2 Load:	0,71	Break Down %	250		

Rotor Inertia Wk2 Lb-Ft2	Max Load Inertia Wk2 Lb-Ft2	Shaft Material	Frame Material	DE Bracket Type	ODE Bracket Type	Enclosure	NEMA Rating	Lead Wire Size
109,16	2170	Standard	Cast Iron	Standard	Standard	TEFC	IP55	4AWG

Ball Bearings		Grease	Mount Type	Orientation	Paint	Sound Pressure @ 3FT	Sound Power
DE	ODE						
NU319	6318	Mobil PolyrexEm	Rigid	Horizontal	Green	86	98

Inverter Duty. Motor meets MG1 parts 31.4.4.2	Constant Torque Range	Variable Torque Range	Constant HP RPM
		10:1	20:1

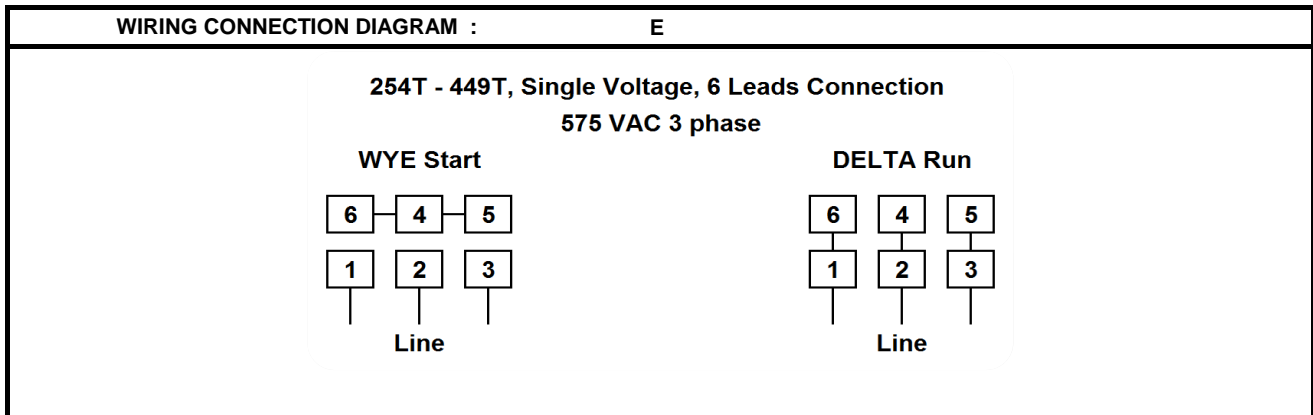

Date: 2020-02-27  
 Customer: \_\_\_\_\_  
 Contact: \_\_\_\_\_  
 Submittee: J.C. Lavallée

Catalogue #: MPP-88

NEMA PREMIUM NR CAN NEMA 12 - 12										
HP	VAC	RPM	Enclosure	Frame	Frequency	Design	Poles	LR Code Letter	Insulation Class	Temp. Rise °C
150	575	1188	TEFC	447T	60	B	6	G	F	< 80
	0Hz	6Hz	15Hz	30Hz	45Hz	60Hz	75Hz	90Hz	105Hz	120Hz
Amps	143,2	143,2	143,2	143,2	143,2	143,2	143,2	143,2	143,2	143,2
RPM	0	118,8	297	594	891	1188	1485	1782	2079	2376
Torq ft.lb	530,51	663,13	663,13	663,13	663,13	663,13	530,51	442,09	378,93	331,57
Peak Tq ft.lb	746,02	1492,05	1492,05	1492,05	1492,05	1492,05	1193,64	994,70	852,60	746,02
HP	0	15,0	37,5	75,0	112,5	150,0	150,0	150,0	150,0	150,0
	Locked Rotor	Pull-Up	Breakdown	Rated Load	Idle	Duty	S. F.	Ambient	Elevation	dBA @ 1M
Speed (RPM)	0,0	504	960	1188	1200	Continuous	1,15	40°C	3300 ft	86
Current (Amps)	868,0	737,8	516,5	143,2	35,9	VFD Rating: Meets MG1 parts 31.4.4.2				
Torque (ft-lbs)	928,4	696,3	1657,8	663,1	0,0	C.T.	10:1	V.T.	20:1	

Motor Speed Data

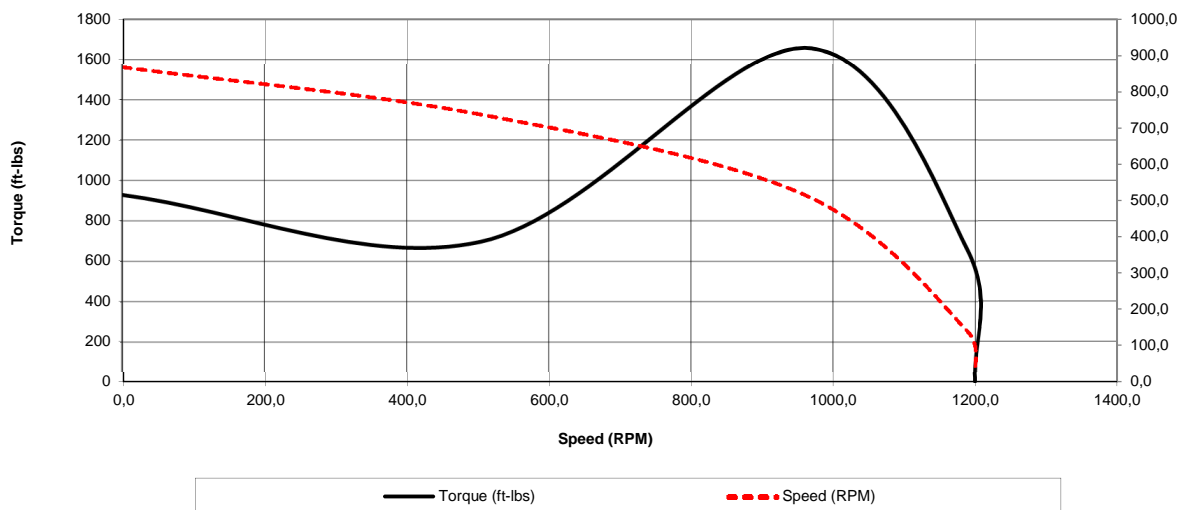

Motor Torque Capability vs RPM

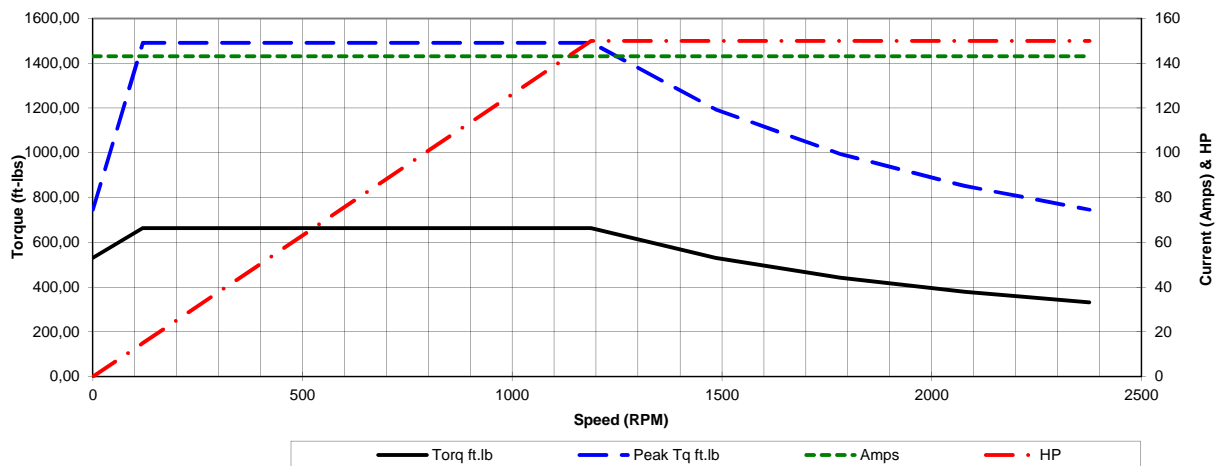



Date: 2020-02-27  
 Customer: \_\_\_\_\_  
 Contact: \_\_\_\_\_  
 Submittee: J.C. Lavallée

Catalogue #: **MPP-88**

NEMA PREMIUM NR CAN NEMA 12 - 12										
HP	VAC	RPM	Enclosure	Frame	Frequency	Design	Poles	LR Code Letter	Insulation Class	Temp. Rise °C
150	575	1188	TEFC	447T	60	B	6	G	F	< 80
Load %	0%	25%	50%	75%	100%	125%	150%			
Amps	35,94	51,19	78,62	109,55	143,20	174,53	211,96			
Torq ft/lbs	0	164,54	329,90	496,10	663,13	831,01	999,75			
RPM	0	1197	1194	1191	1188	1185	1182			
Eff	0	88,50	94,50	95,10	95,80	95,80	95,80			
PF	0	62	71	79	82	84	83			
	Locked Rotor	Pull-Up	Breakdown	Rated Load	Idle	Duty	S. F.	Ambient	Elevation	dBA @ 1M
Speed (RPM)	0	504	960	1188	1200	Continuous	1,15	40°C	3300 ft	86
Current (Amps)	868	737,8	516,5	143,2	35,9432	VFD Rating: Meets MG1 parts 31.4.4.2				
Torque (ft-lbs)	928,38	696,29	1657,83	663,13	0,0	C.T.	10:1	V.T.	20:1	

